

FINEX SIEVES PVT. LTD. *India's Leading Designer Manufacturer of Powder processing machines Grinding, Screening, Mixing, Drying, Material Handling Equipments and plants. We are a 22 years old Company and Leaders in Powder Processing Tech Designing and Manufacturing Cutting Edge Innovative Products for the processing industries. We supply all over the world. We are located in Baroda Gujarat India's Largest Engineering Industrial Estate. Gujarat is India's Largest Industrial State. We are located in Baroda Gujarat India's Largest Engineering Industrial Estate. Gujarat is India's Largest Industrial State. We are having a Land Area of 26,000sq.ft. area and built up Area of 7500sq. ft.*

FINEX SIEVES PVT. LTD.

606, GIDC MAKARPURA, VADODARA, GUJARAT,

INDIA, PH: 91-265-2642214, FAX: 91-265-2311871,

MOB: 9376232820

Visit site www.finexsieves.com

Email: contact@finexsieves.com

fsieves@yahoo.com

FINEX ROTARY DRUM SIFTERS SRX Series For Large Fine powder separations

This is a Rotating Drum Sifter for low Density non abrasive powders specially for screening powders from 10 mesh to 300 mesh. Material is fed in to a Screw Feeder with flat paddles which rotates at a speed from 60 to 120rpm.. The powder is thrown outwards by Centrifugal motion to a Rotating Screen Drum that also rotates in same or opposite direction at a speed from 60 to 100rpm. Often on the Rotating flat paddles brushes or flat wipers of pvc or Teflon are fitted this scrapes along the screen area keeping the screen clean from blinding . Screened powder is discharged below in to a Screw conveyor below from which bagging of powder is done.

Rotary Sifters have screening Drums of various sizes from 1 meter long to 5 meters long .

Applications are for screening Grading powders from 60 mesh to 300mesh. Can handle from 1000kgs/hr to 5000Kgs/hr .

For Chemicals , Foods, Cosmetics, Plastics, Wood flour etc. Fabricated in Carbon steel, Stainlesssteel, Mild Steel.

MODEL	HP	SCREENING AREA	
SR2X	2HP 2Nos	1000mm Long	by 600mm dia
SR3X	3HP 2Nos	1500mm Long	by 750mm dia
SR5X	5HP 3Nos	2000mm Long	by 750mm dia
SR6X	5HP 3nos	3000mm Long	by 750mm dia

POWDER PROCESSING PRODUCT RANGE OF FINEX EQUIPMENTS AND PLANTS

<p><u>GRINDING EQUIPMENT</u></p> <p>Hammer Mills Pin Mill Micro Mills Plastic Grinding Mills Ultra Fine Mills Air Swept Mills Lump Crushers</p>	<p><u>SCREENING EQUIPMENT</u></p> <p>Gyratory Separators Vibratory Graders Rotary Sifters Rotary Drum Sifters Cleaning Graders Air Aspirators Destoners Air Classifiers</p>
<p><u>MATERIAL HANDLING SYSTEMS</u></p> <p>Screw Conveyors Vibratory Feeders Bucket & Belt Conveyor PJ Dust Collectors Rotary Airlock Valves Pneumatic Conveying Systems</p>	<p><u>DRYERS & ROASTERS</u></p> <p>Pneumatic Dryers Flash Dryers Roasters <u>CONTINUOUS FLUID BED PNEUMATIC DRYING PLANTS</u></p>
<p><u>TURNKEY PLANTS</u></p> <p>Salt Refinery Spice Plant Air Classification Plants</p>	<p><u>BLENDERS & MIXERS</u></p> <p>Ribbon Blenders Paddle Blender Drum Mixers</p>

APPLICATIONS

CHEMICALS	PHARMACEUTICAL	COSMETIC	PLASTICS
FILLERS	INSECTICIDES	DETERGENT	PIGMENT
RESINS	SPICES	CERAMICS	FILLERS
CEMENT	FOOD FLOUR POWDER	LIME	MINERAL

FINEX-SR 2X MS



FINEX SR 2X MS



FINEX SR 2X SS



FINEX-SR 2X SS



FINEX SR 2X



FINEX

SR 8X STRACH SIFTER



FINEX SR 3X SS

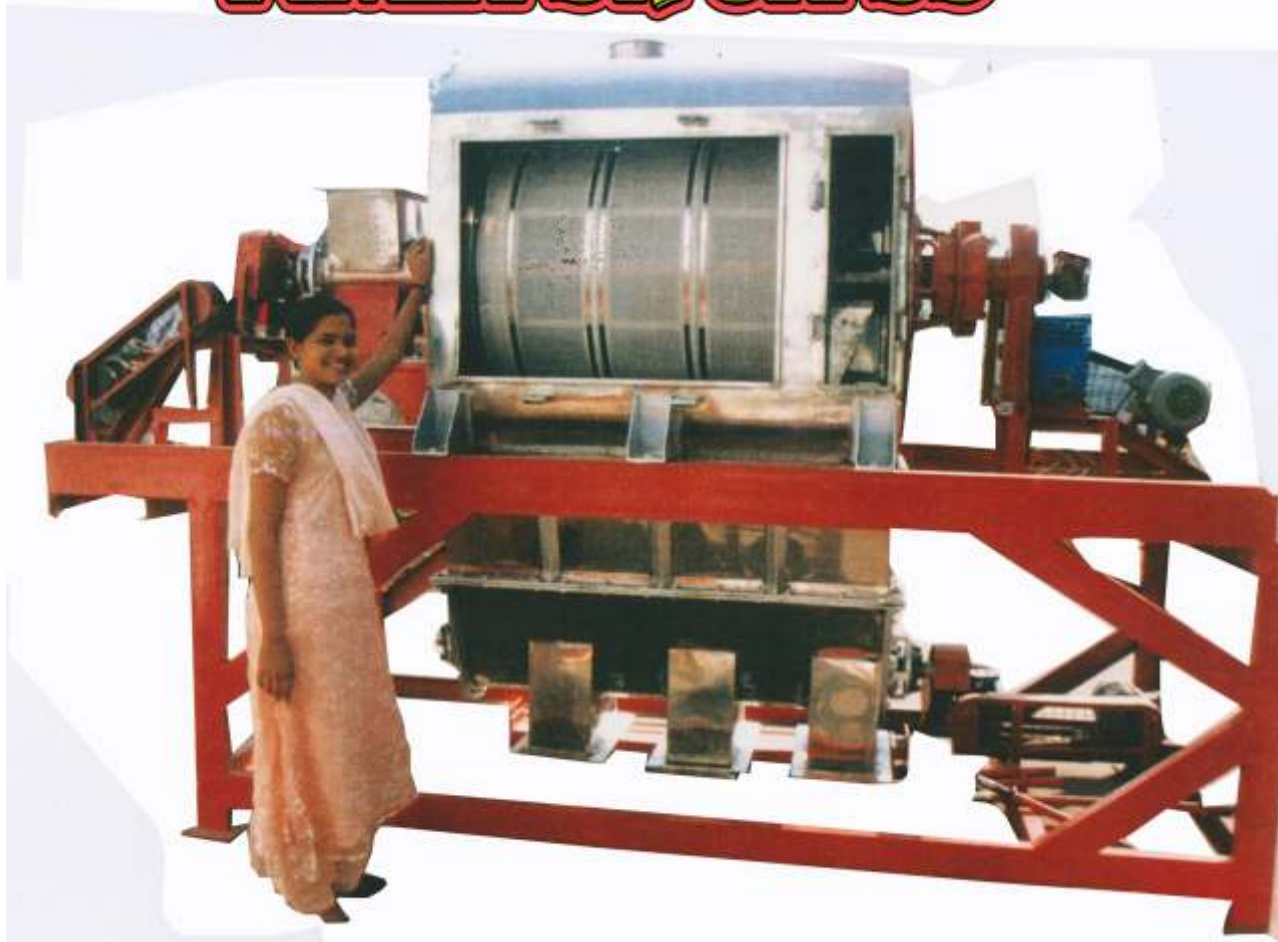

SR 3X ROTARY SIFTER



FINEX -SR 3X



FINEX SR 3X



FINEX-SR 5X SS



FINEX SR 5X



FINEX-SR 5X



FINEX - SR 6X

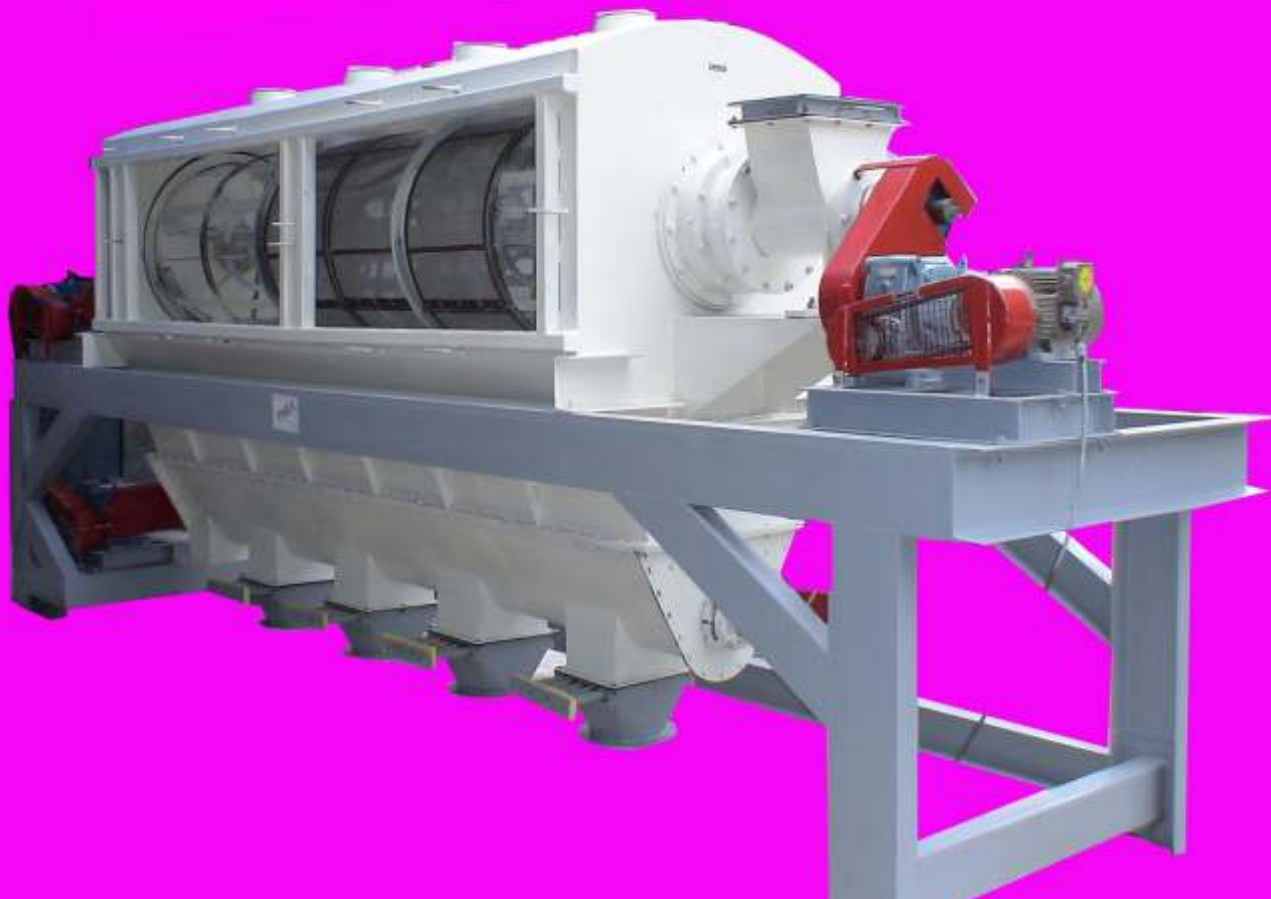

FINEX-SR 6X





FINEX-SR6X

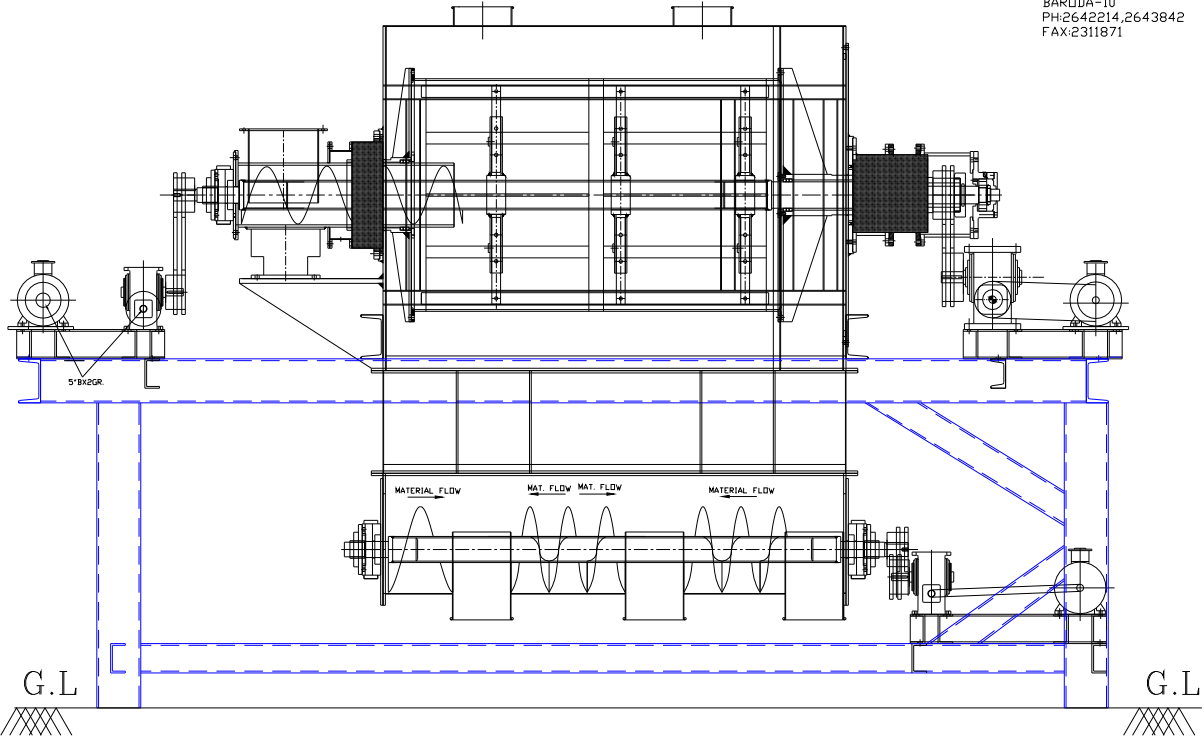

DRG.NO-FSPL/S/R/0003/2006
FINEX SIEVES PVT. LTD.
606 GIDC MAKARPURA,
BARODA-10
PH:2642214,2643842
FAX:2311871

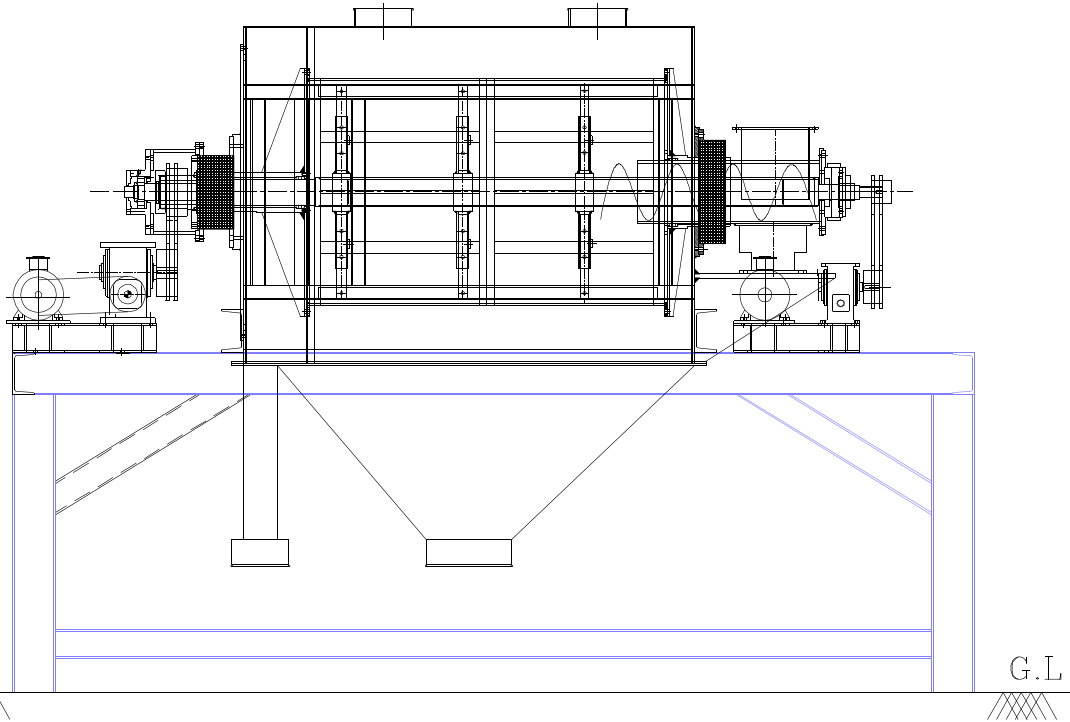



	PART NO.	ALL DIMENSIONS ARE IN MM DRN.NO:-FSPL/600TD/010
	DATE	26/10/08
	CHD	HARDIK
	SCALE	1:1
SR-X		TITLE:-
		ASSEMBLY (BASKET)

FINEX SIEVES PVT.LTD
A1-606 G.I.D.C. BARODA-10