

FINEX SIEVES PVT. LTD. India's Leading Designer
Manufacturer of Powder processing machines Grinding, Screening, Mixing,
Drying, Material Handling Equipments and plants. We are a 22 years old
Company and Leaders in Powder Processing Tech Designing and
Manufacturing Cutting Edge Innovative Products for the processing
industries. We supply all over the world. We are located in Baroda Gujarat
India's Largest Engineering Industrial Estate. Gujarat is India's Largest
Industrial State. We are located in Baroda Gujarat India's Largest
Engineering Industrial Estate. Gujarat is India's Largest Industrial State.
We are having a Land Area of 26,000sq.ft. area and built up Area of
7500sq. ft.

FINEX SIEVES PVT. LTD.

606, GIDC MAKARPURA, VADODARA, GUJARAT,

INDIA, PH: 91-265-2642214, FAX: 91-265-2311871,

MOB: 9376232820

Visit site www.finexsieves.com

Email: contact@finexsieves.com

fsieves@yahoo.com

FOR CHEMICALS FOODS MINERALS ETC

FINEX S.R RANGE OF ROTARY SIFTERS Work on Air Turbulence principal .It is a non Vibrating Rotating Design The screw feed impellor conveys the infeed material to the stationary screen basket on which is fitted the screen .Teflon blades or soft nylon brushes are fitted on the rotating Impellor that keeps the screen basket clean. Impellor is driven by Direct drive or pulley drive 1440rpm tefc motor Speed is from 600 TO 1200RPM

This Design is suitable for low bulk density non abrasive powders specially good for screening from 60 to 200mesh powders in a dustproof environment .Also works well for sticky hydroscopic powders.

Screening capacity Range is from 100kgs/hr to 2000kgs/hr.
Available in stainless steel and Mild steel construction.

FINEX GMP S.R RANGE OF ROTARY SIFTERS Work on Air Turbulence principal .It is a non Vibrating Rotating Design .The screw feed impellor conveys the infeed material to the stationary screen basket on which is fitted the screen .Teflon blades or soft nylon brushes are fitted on the rotating Impellor that keeps the screen basket clean. Impellor is driven by Direct drive BY. 1440rpm tefc motor .Speed is from 600RPM TO 1200 RPM BY VFD DRIVE .

This Design is suitable for low bulk density non abrasive powders specially good for screening from 60 to 200mesh powders in a dustproof environment .Also works well for sticky hydroscopic powders.

Screening capacity Range is from 100kgs/hr to 2000kgs/hr.

Available in stainless steel. GMP construction.

GMP IS ALL PRODUCT CONTACT PARTS OF 316 .

CREVICE FREE DESIGN NO POWDER ACCUMALATION AT ANY JOINTS .

EASY TO DISMANTLE AND REASSEMBLE WITHOUT TOOLS
MEETS FDA STANDARDS IN WORKMANSHIP AND
OPERATION

NON PRODUCT CONTACT PARTS OF SS304 .

POWDER PROCESSING PRODUCT RANGE OF FINEX EQUIPMENTS AND PLANTS

<p><u>GRINDING EQUIPMENT</u></p> <p>Hammer Mills Pin Mill Micro Mills Plastic Grinding Mills Ultra Fine Mills Air Swept Mills Lump Crushers</p>	<p><u>SCREENING EQUIPMENT</u></p> <p>Gyratory Separators Vibratory Graders Rotary Sifters Rotary Drum Sifters Cleaning Graders Air Aspirators Destoners Air Classifiers</p>
<p><u>MATERIAL HANDLING SYSTEMS</u></p> <p>Screw Conveyors Vibratory Feeders Bucket & Belt Conveyor PJ Dust Collectors Rotary Airlock Valves Pneumatic Conveying Systems</p>	<p><u>DRYERS & ROASTERS</u></p> <p>Pneumatic Dryers Flash Dryers Roasters</p> <p><u>CONTINUOUS FLUID BED PNEUMATIC DRYING PLANTS</u></p>
<p><u>TURNKEY PLANTS</u></p> <p>Salt Refinery Spice Plant Air Classification Plants</p>	<p><u>BLENDERS & MIXERS</u></p> <p>Ribbon Blenders Paddle Blender Drum Mixers</p>

APPLICATIONS

CHEMICALS	PHARMACEUTICAL	COSMETIC	PLASTICS
FILLERS	INSECTICIDES	DETERGENT	PIGMENT
RESINS	SPICES	CERAMICS	FILLERS
CEMENT	FOOD FLOUR POWDER	LIME	MINERAL

A unique name for manufacturing machines for Grinding , Screening , Mixing , Drying , Material Handling , Equipments & Plants.

➔ **SCREENING MODELS:-**

➔ TECHNICAL DATA :-

MODEL NO.	MOTOR (H.P.)	CAPACITY (Kg / hr.)
SR 350	01	100
SR 750	03	500
SR 1200	05	1000
SCREENING FROM 60 TO 300 MESH		

➔ DIMENSION TABLE :-

MODEL NO.	Ø Di	Ø Do	H0	Gd	Z	GL X GB	TL X TB
SR 350	126	140	1140	590	740	510 X 400	830 X 320
SR 750	146	200	1500	800	970	1100 X 500	1400 X 430
SR 1200	160	270	1600	600	750	1400 X 900	830 X 320
ALL THE DIMENSIONS ARE IN MM							

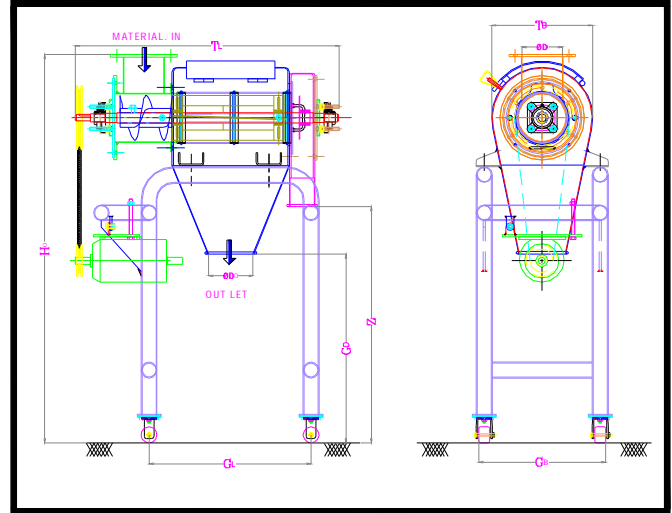

SR 750



SR-750



SR-750



SR 750 S.S



SR 750 M.S



SR 750 M.S

